

Задача 2. Определение реакций опор составной конструкции

(система двух тел)

Конструкция состоит из двух частей. Определить все реакции в опорах, при этом в соединении С рассматривать неподвижный шарнир.

Таблица

Номер вариан- та	P ₁	P ₂	M, кН·м	q, кН/м	Номер вариан- та	P ₁	P ₂	M, кН·м	q, кН/м
	кН					кН			
1	5,0	-	24,0	0,8	16	7,0	10,0	14,0	3,8
2	6,0	10,0	22,0	1,0	17	9,0	12,0	26,0	4,0
3	7,0	9,0	20,0	1,2	18	11,0	10,0	18,0	3,5
4	8,0	-	18,0	1,4	19	13,0	9,0	30,0	3,0
5	9,0	-	16,0	1,6	20	15,0	8,0	25,0	2,5
6	10,0	8,0	25,0	1,8	21	10,0	7,0	20,0	2,0
7	11,0	7,0	20,0	2,0	22	5,0	6,0	15,0	1,5
8	12,0	6,0	15,0	2,2	23	8,0	5,0	10,0	1,4
9	13,0	-	10,0	2,4	24	11,0	4,0	5,0	1,3
10	14,0	-	12,0	2,6	25	14,0	6,0	7,0	1,2
11	15,0	5,0	14,0	2,8	26	12,0	8,0	9,0	1,1
12	12,0	4,0	16,0	3,0	27	10,0	7,0	11,0	1,0
13	9,0	6,0	18,0	3,2	28	8,0	9,0	13,0	1,2
14	6,0	-	20,0	3,4	29	6,0	10,0	15,0	1,4
15	5,0	8,0	22,0	3,6	30	10,0	12,0	17,0	1,6

21

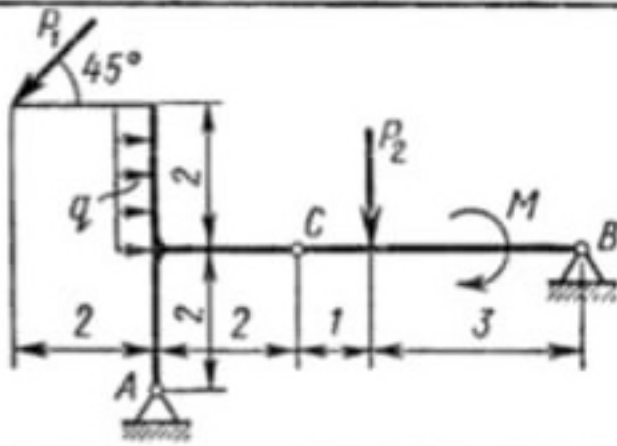

22

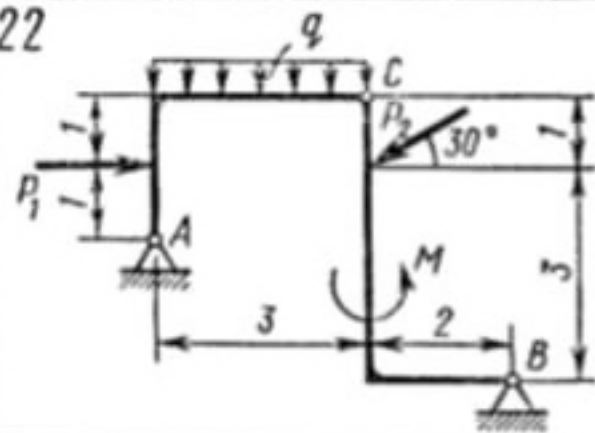

23

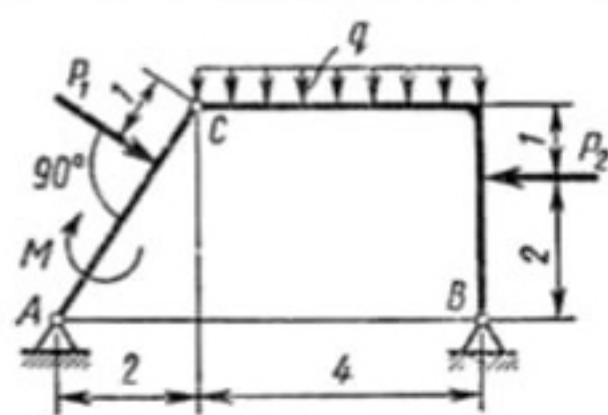

24

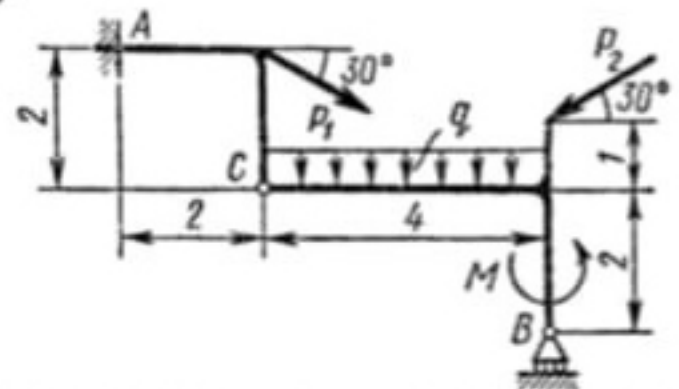

25

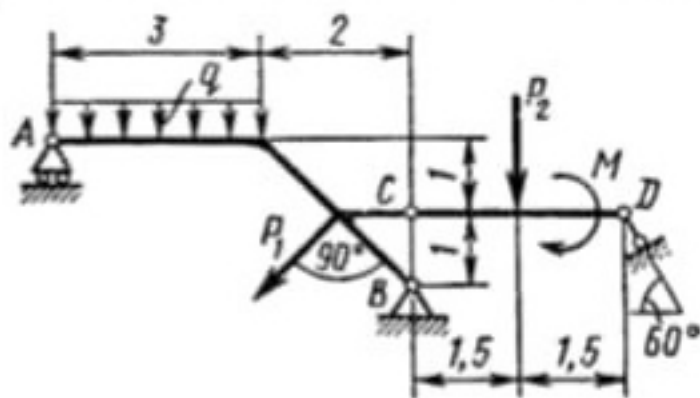

26

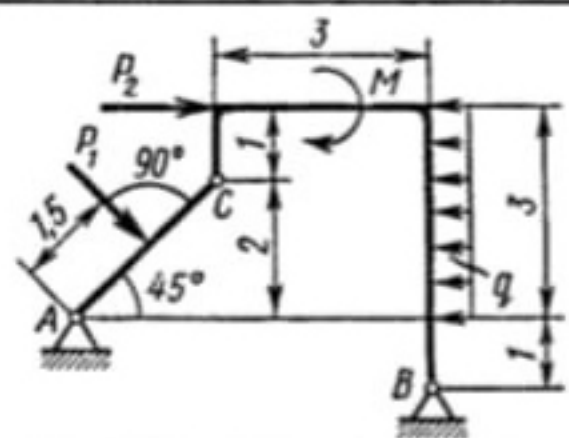

27

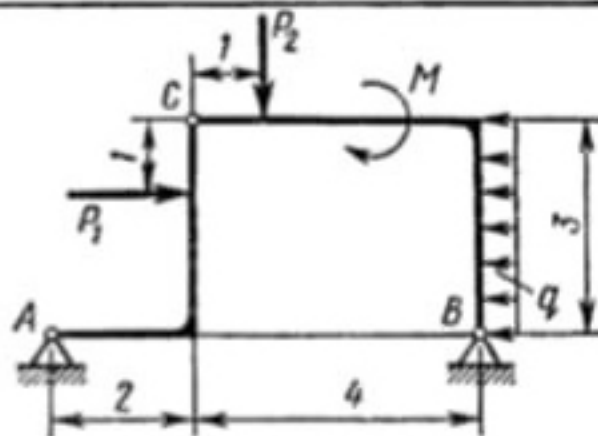

28

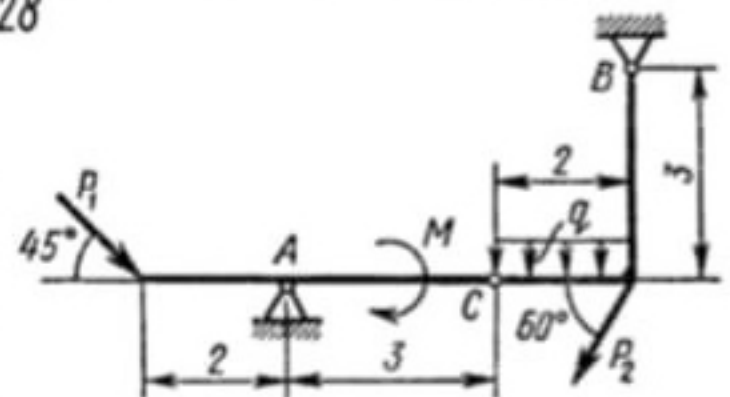

29

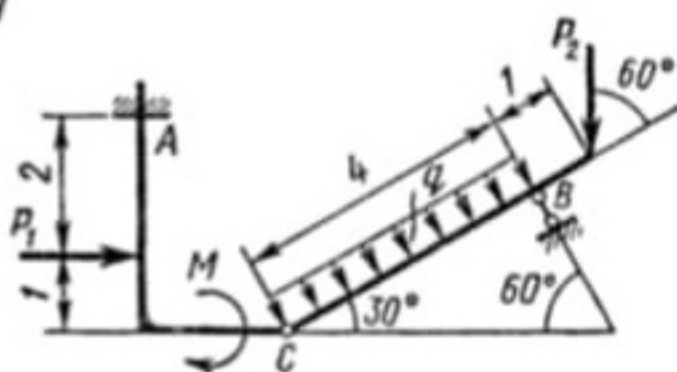

30

